

VINDOW

The European Touch

THE ART OF WINDOWS AND DOORS:

Made in Europe, Designed for Canada

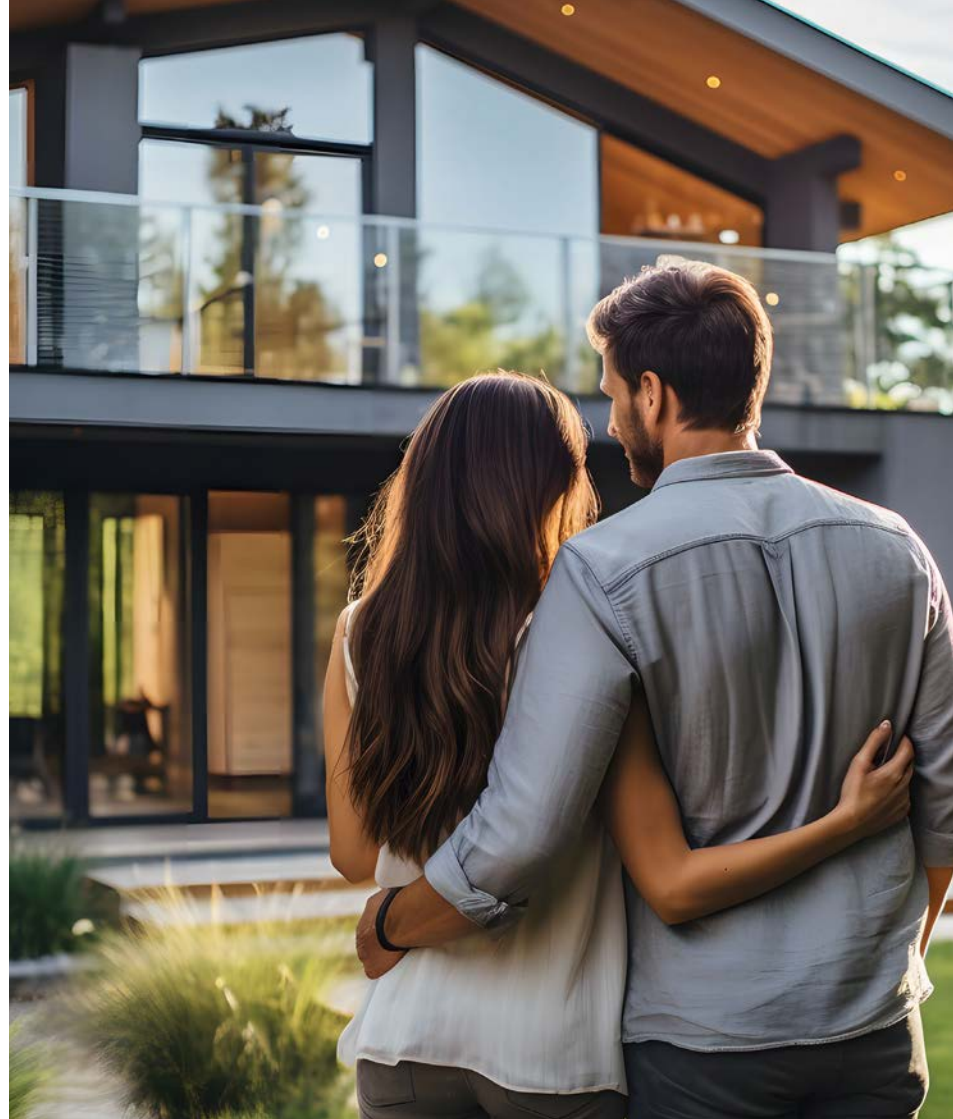

Table of Contents

01 ABOUT	2
02 MINIMAL DESIGN SYSTEMS	6
03 ARCHITECTURAL SYSTEMS	8
04 ENTRANCE DOORS	18
05 RAILINGS	10
06 INSPIRATIONAL PROJECTS	12



A Warm Welcome to Vindow

At Vindow Canada, we bring together European elegance and the unique needs of Canadian homes. As a proud Canadian company, we deliver impeccable craftsmanship and cutting-edge German technology in every window and door. Our solutions combine modern design, energy efficiency, and durability, ensuring your home is both beautiful and functional. With over 35 years of combined industry experience, our skilled experts provide personalized service and support. We guide you through every step of your project for complete peace of mind.



Why Window

European Craftsmanship_ We specialize in high-quality aluminum windows and doors, crafted to resist warping, cracking, and fading for lasting durability.

Larger, Custom Designs_ We offer large-format windows up to 3 meters wide and 10 meters tall.

Advanced Energy Efficiency_ Our double or triple glazing, Low-E coatings, and thermal break systems block up to 95% of UV rays, exceeding industry energy efficiency standards.

Compliance with Standards_ Our products meet BC Energy Step Code 3, a benchmark for energy efficiency in British Columbia, Ontario, and Quebec.

Built for Canadian Weather_ Our systems are designed to withstand Canada's harsh climate, providing superior air permeability, water resistance, and wind load capacity.

Unparalleled Security_ Protect your home with anti-burglary features like reinforced aluminum frames and multi-point locking systems.

Warranties_ Enjoy up to 20-year warranties.

Exceptional Customer Service_ Our dedicated team assists you every step of the way.

Hassle-Free Installation_ Our in-house team ensures a perfect fit and optimal performance.

Quick Supply of Parts_ We offer fast delivery of handles and parts within one week to keep your project on track.

Financing Options_ We aim to make it easy for you to equip your home with top-quality windows and doors. We believe you shouldn't have to compromise between performance and affordability. That's why we work with trusted partners who offer a range of payment plans and financing options.

Window PanoramaView

Ultra-slim frames for unobstructed views.

The SCHÜCO ASE 67 PD features one of the slimmest profiles available, offering expansive, panoramic views and a minimalist aesthetic for modern homes.



reddot design award
winner 2019

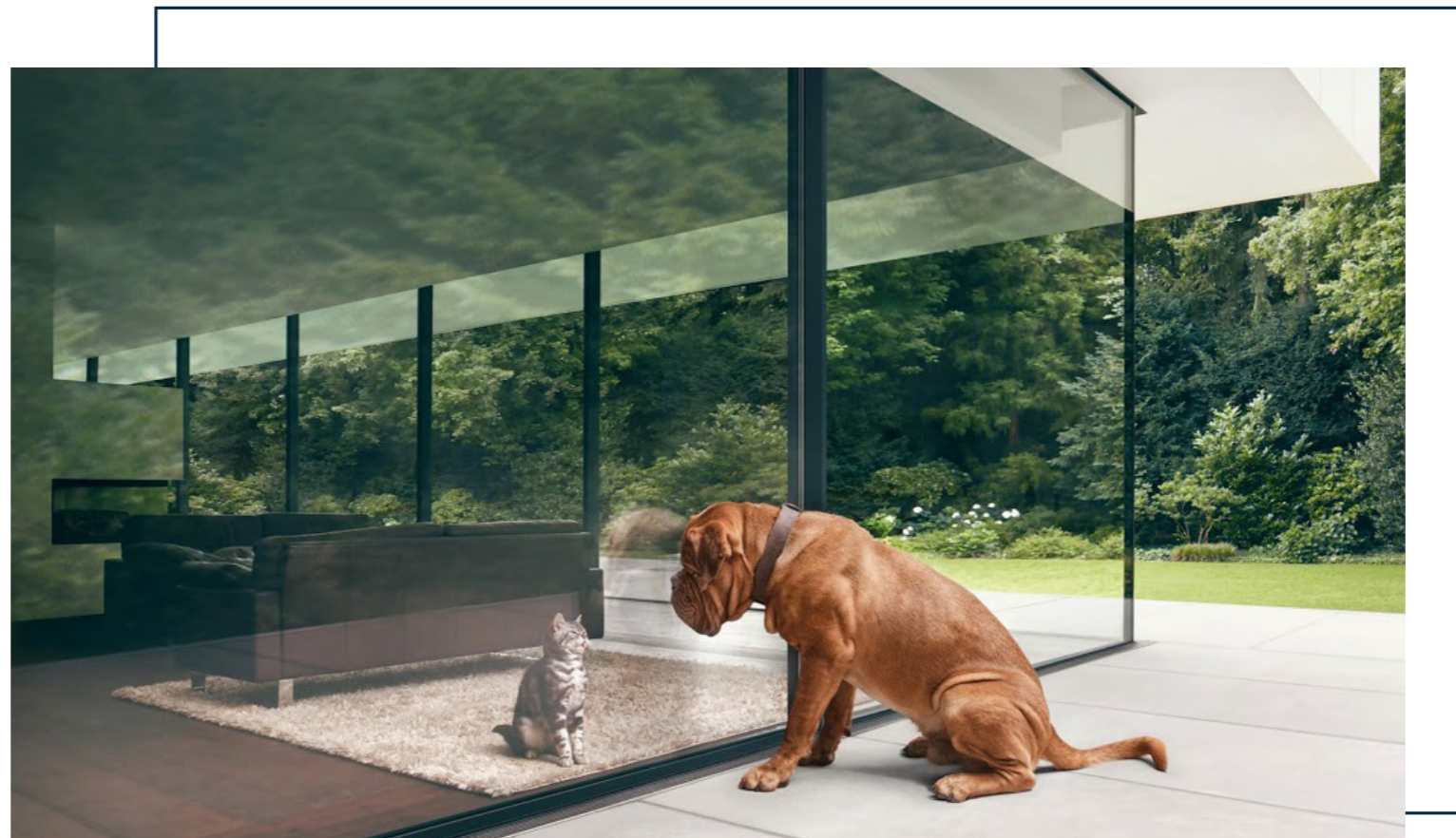

Window SlimTherm

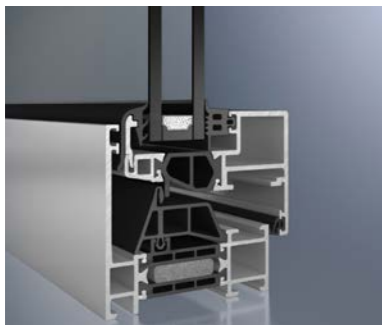

Slim profile with excellent thermal insulation.

The SCHÜCO AWS 70 BS.HI combines a sleek design with outstanding thermal performance, perfect for homes that need both style and energy efficiency.

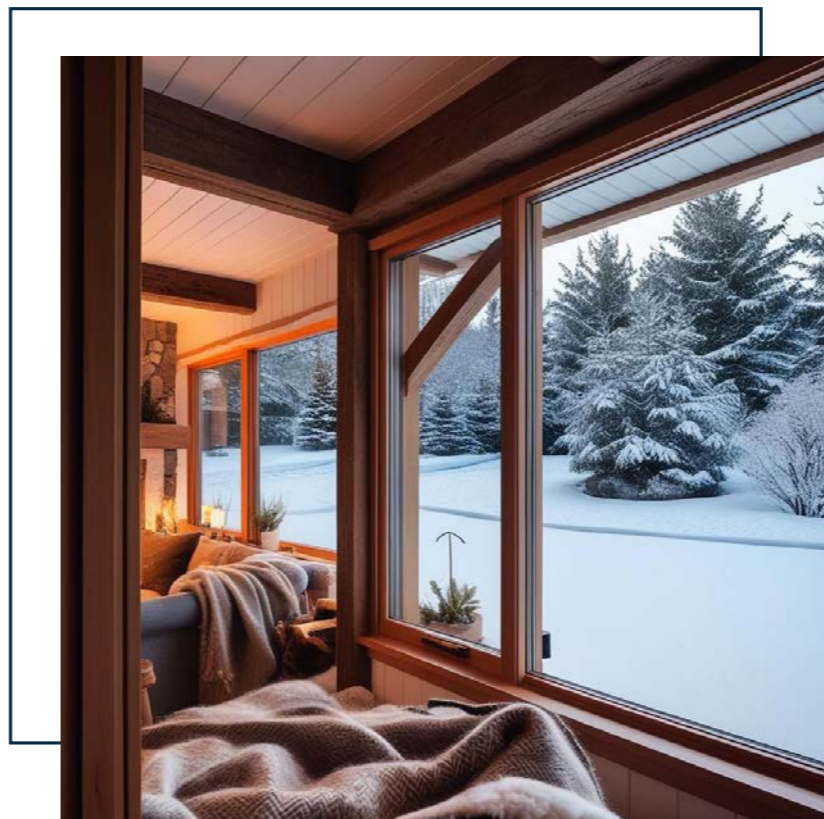

Window ArcticGuard

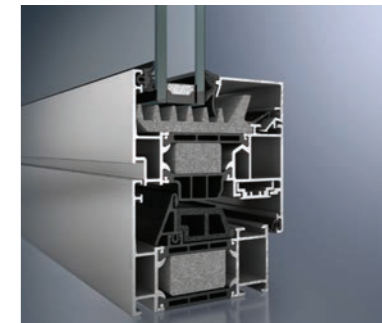

Top-tier energy efficiency for year-round comfort.

Engineered for extreme conditions, the SCHÜCO AWS 75.SI+ excels in energy efficiency, keeping your home cozy in winter and cool in summer.

Window HorizonFlex



Seamless transitions and ultimate customization.

The SCHÜCO ASS 50 and ASE 60 systems provide expansive sliding openings that blend indoor and outdoor spaces, ideal for modern living. With a modular design, these systems offer ultimate flexibility in configuration, making them adaptable to various spaces and styles while creating wide, panoramic views.



Window FoldVista



Bi-fold system for wide, unobstructed views.

The SCHÜCO ASS 70 FD offers wide-open views with a bi-fold system, seamlessly connecting your indoor and outdoor spaces.



Window ArchiFlex Curtainwalls



Versatile façade system for striking architectural designs.

The SCHÜCO FWS 50 provides maximum flexibility for bold architectural projects, offering various configurations for walls and skylights.



Window Passive House Grande

Size, design, and energy efficiency.

The ARTEVO Tilt-Turn Window by REHAU emphasizes large, customizable sizes with sleek, modern aesthetics, delivering superior thermal and acoustic insulation for enhanced comfort and security.



RAU-FIPRO X
High-Tech
Material

REHAU EcoPuls
Sustainability
Competence





Key Features of Our Windows

Exceptional Sound Insulation_ Rated up to Rw 48 dB, our windows block out city noise, providing a peaceful escape, perfect for busy cities like Toronto or Vancouver.

Superior Thermal Insulation_ Superior Thermal Insulation: With a U_w value up to $0.7W/(m^2 \cdot K)$, our windows keep your home cozy in Canada's harsh winters and cool in summer, saving on energy bills while complying with the new Canadian standards for energy efficiency.

Effortless Operation & Weather Resistance_ Engineered to glide smoothly, supporting up to 400 kg, and designed to withstand Canada's snow, rain, and wind.

UV Protection_ Effectively blocks harmful ultraviolet rays, safeguarding your flooring, furniture, and interior décor from fading over time.

Customizable Design & Security_ Slim profiles maximize natural light, and advanced locking systems ensure safety, while laminated glass enhances security and aesthetics with versatile, tailor-made designs for your home.

Custom Colors_ Choose from 300 STATURA or RAL colors at no additional cost beyond the standard white or black.

Doors

The Art of Entry

Our collection of doors presents exceptional and stylish solutions, crafted to transform spaces and create captivating effects.

Types of Doors: Hinged doors, pivot doors, and sliding doors

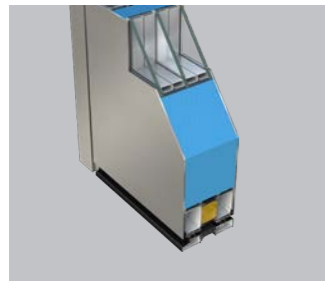

Pivot

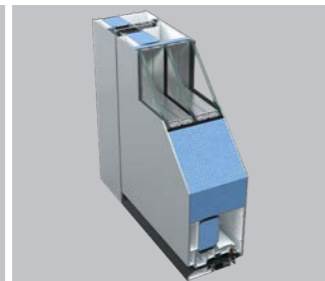

Flush



Design & Customization

“Design is not just what it looks like and feels like. Design is how it works.” – Steve Jobs

At Window, our premium accessories combine style, security, and convenience.

Stylish Handles & Hinges

Vision Handles_ Sleek, modern design

Soft Touch Handles_ Ergonomic comfort

Fingerprint Scanners_ Keyless entry on select models

Custom Colors_ Available in unique STATURA or RAL shades like Black,

Mystique,



Mystique Edition

Twelve unique color textures.

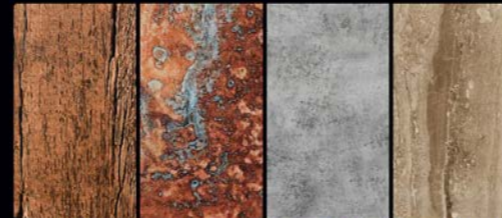

Old Wood Copper Patina Concrete Gray Brown Marble

Wood Colors

Twenty four wood and earth material imitation colors.



T630 T631 T945 T875

RAL Colors

Dozens of RAL colors in texture finish.



7001 3004 7016 8017



Additional Features

High-Security Locking Systems_ Advanced multi-point locks with reinforced strike plates and sleek handles

Smart Access Control_ Digital keypads, smart locks, and fingerprint recognition for keyless entry

Weatherproofing Solutions_ Designed to withstand harsh elements while maintaining energy efficiency

Quick Delivery_ Accessories are available within a week to minimize delays

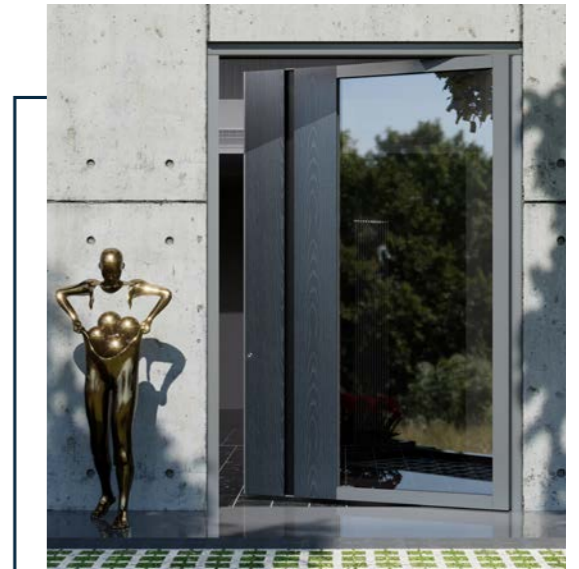

Have a look & get inspired

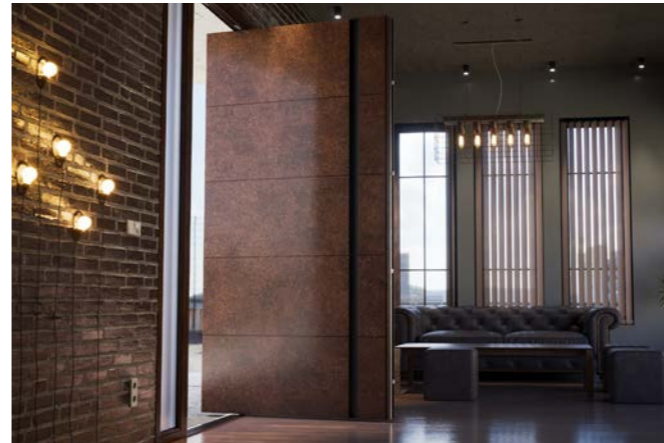
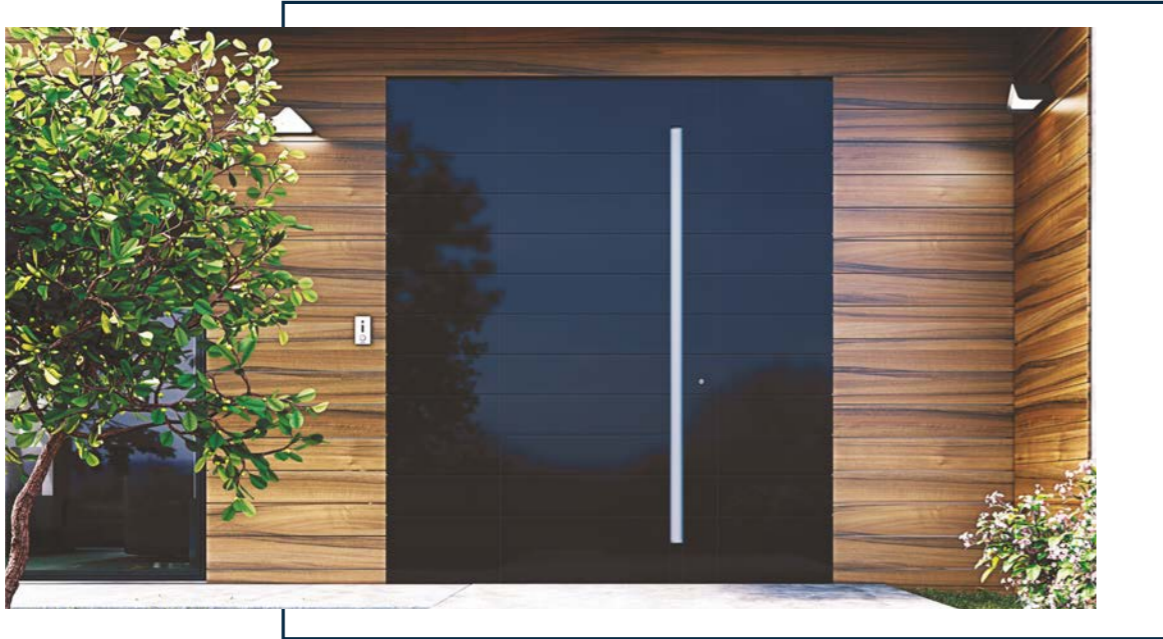



Colors and Textures for Every Canadian Landscape

From the snowy peaks of the Rockies to the shores of Prince Edward Island, our aluminum windows and doors are engineered to withstand diverse weather conditions while preserving their beauty. Choose a color and texture that not only complements your home's style but also resonates with the natural surroundings of your specific Canadian locale. Each option is available in a variety of finishes, ensuring both durability and aesthetic perfection for any environment.

Welcome to Our Winter Wonderland



Concrete Gray (ME 30)

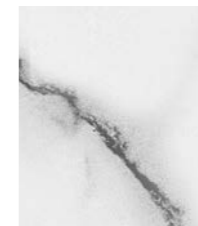

White Marble (ME 21)



Natural Wood (ME 40)

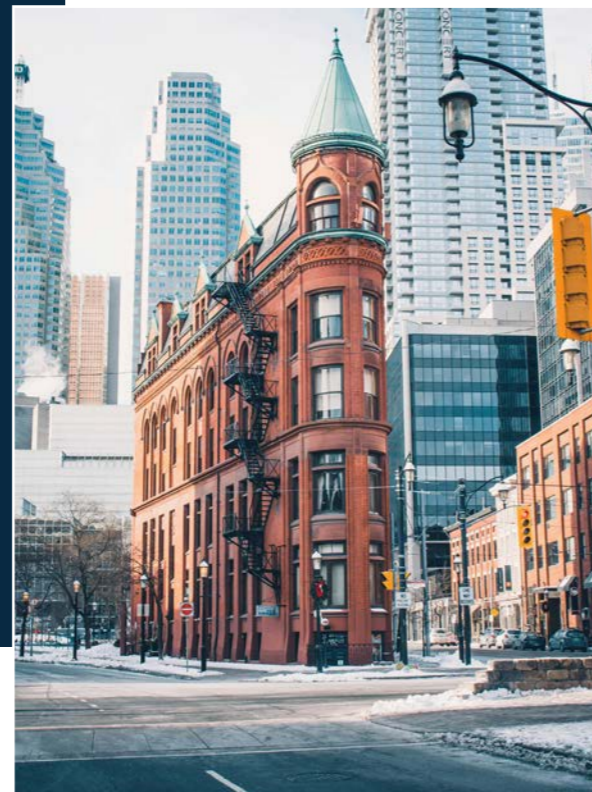

Colors and Textures for Every Canadian Landscape

Welcome to Our Urban Reflections

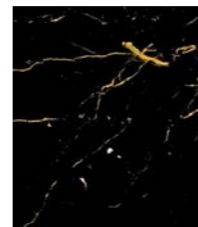

Black Marble (ME 20)



Concrete Gray (ME 30)



Copper Patina (ME 11)

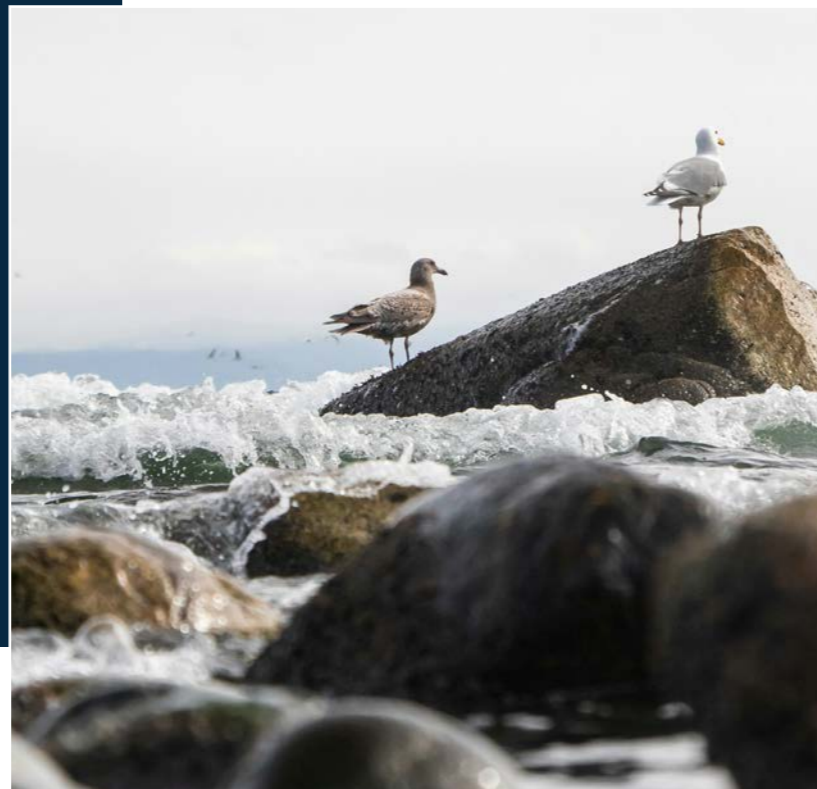

Colors and Textures for Every Canadian Landscape

Welcome to Our Coastal Mist



Rustic Patina (ME 10)



Concrete Gray (ME 30)



Brown Leather (ME 50)

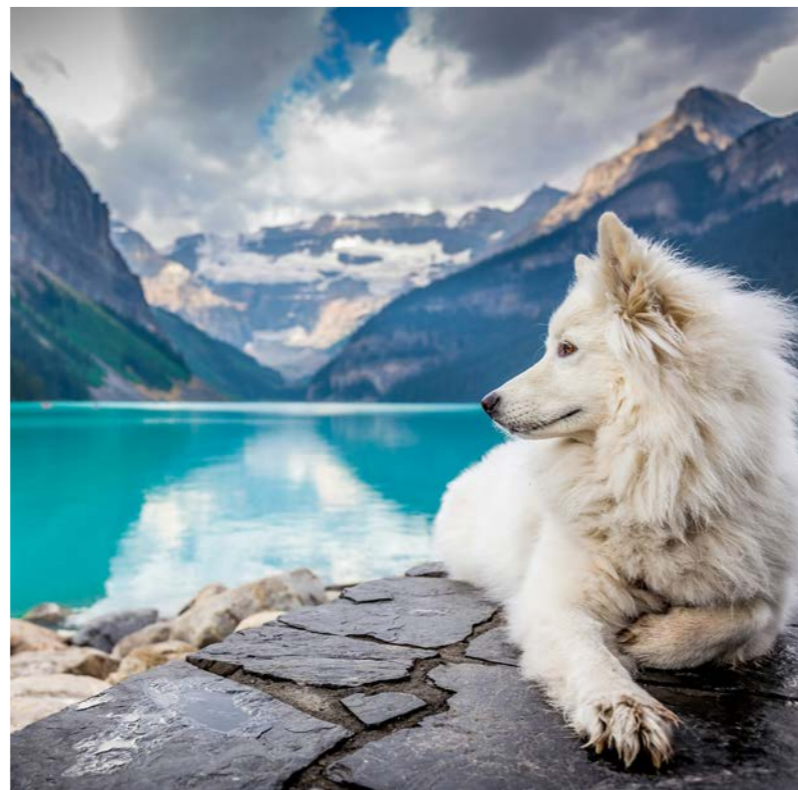

Colors and Textures for Every Canadian Landscape

Welcome to Our Mountain Lake

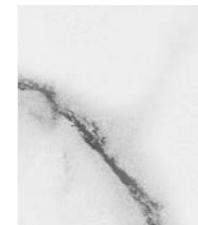

White Marble (ME 21)



Bark Wood (ME 42)



Old Wood (ME 41)

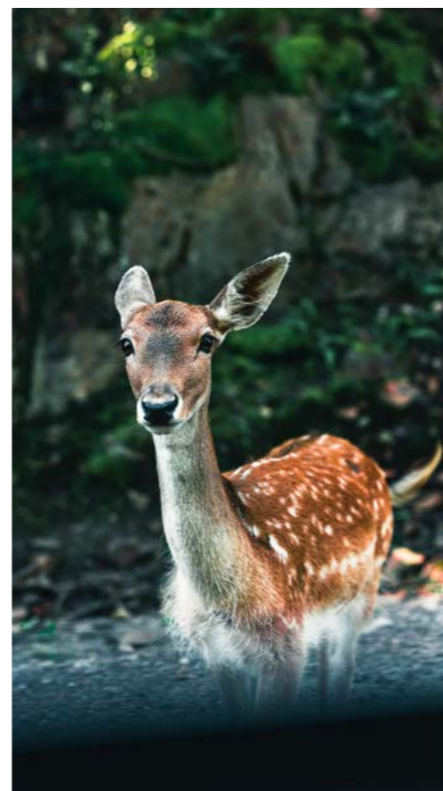

Colors and Textures for Every Canadian Landscape

Welcome to Our Prairie Wildlife



Corten Patina (ME 12)



Natural Wood (ME 40)



Brown Marble (ME 22)

Railings

Vindow's railing systems combine European craftsmanship with North American standards, ensuring safety, durability, and design flexibility across Canada's diverse climates and architectural styles. These low-maintenance systems meet North American codes and deliver custom solutions for residential, commercial, and public spaces, ideal for family-friendly and high-exposure environments.

Aluminum Railing Systems

Key Features_ Corrosion-resistant 6063-T5 aluminum, powder-coated for UV/moisture protection; available heights from 900mm to 1200mm.

Load Capacity_ Supports up to 1.5 kN/m, suitable for various outdoor applications.

Applications_ Balconies, pool enclosures, staircases, garden fencing.

Compliance_ Certified to IBC and IRC standards for outdoor resilience.



Hybrid Railing Systems

Key Features_ Combines 8mm to 1752mm glass with aluminum frames, LED lighting compatible.

Load Capacity_ Supports up to 2.0 kN/m, ideal for decks and multi-story buildings.

Applications_ Decks, stairways, mezzanines, urban settings requiring visibility and safety.

Compliance_ Meets ASTM E985 and IBC for impact and structural integrity.



Glass Railing Solutions

Variety_ 16+ solutions, including the frameless Crystal Line Glass System, perfect for panoramic views in Canadian landscapes.

Key Features_ 10mm to 2152mm tempered or laminated glass anchored in anodized aluminum.

Load Capacity_ Supports up to 3 kN/m, ideal for high-wind and high-traffic areas.

Applications_ Residential/commercial balconies, rooftop patios, pool enclosures.

Compliance_ Meets IBC and ASTM E2353 for impact resistance in Canadian weather.

Your Home with a European Touch

Explore our inspiring projects. Discover innovative designs and cutting-edge solutions crafted to transform and elevate any space.

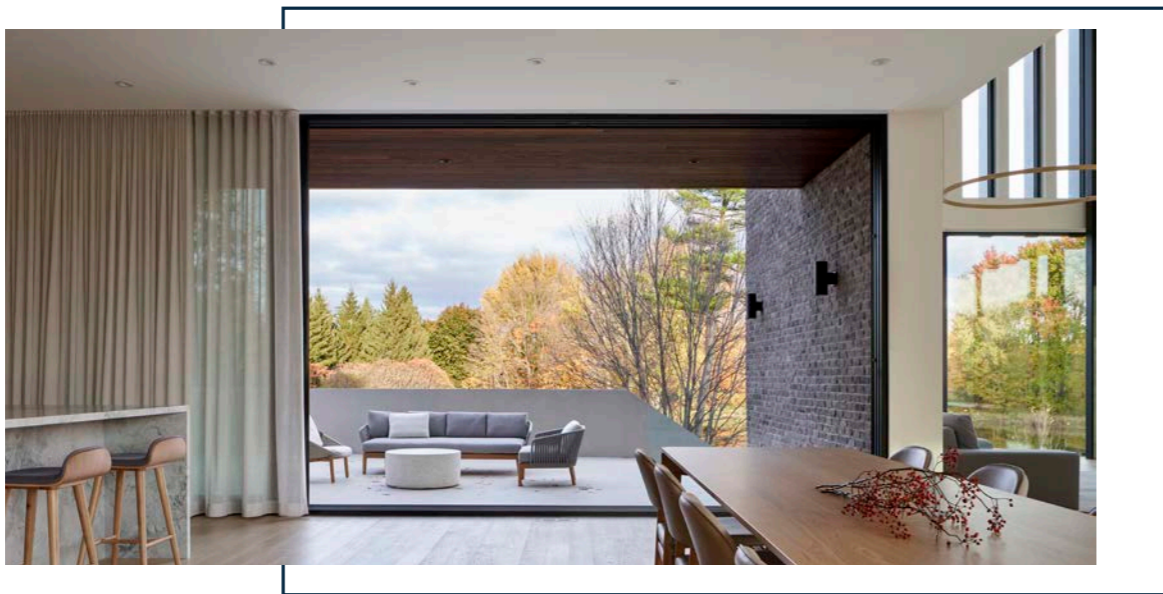



Consider the following factors when making your decision_

Your budget_ Different systems have varying price points

Your home's style_ Choose a system that complements your home's architecture

Your priorities_ Determine whether you prioritize aesthetics, energy efficiency, security, or a combination of these factors

Your lifestyle_ Consider how you will use the windows and what features are most important to you

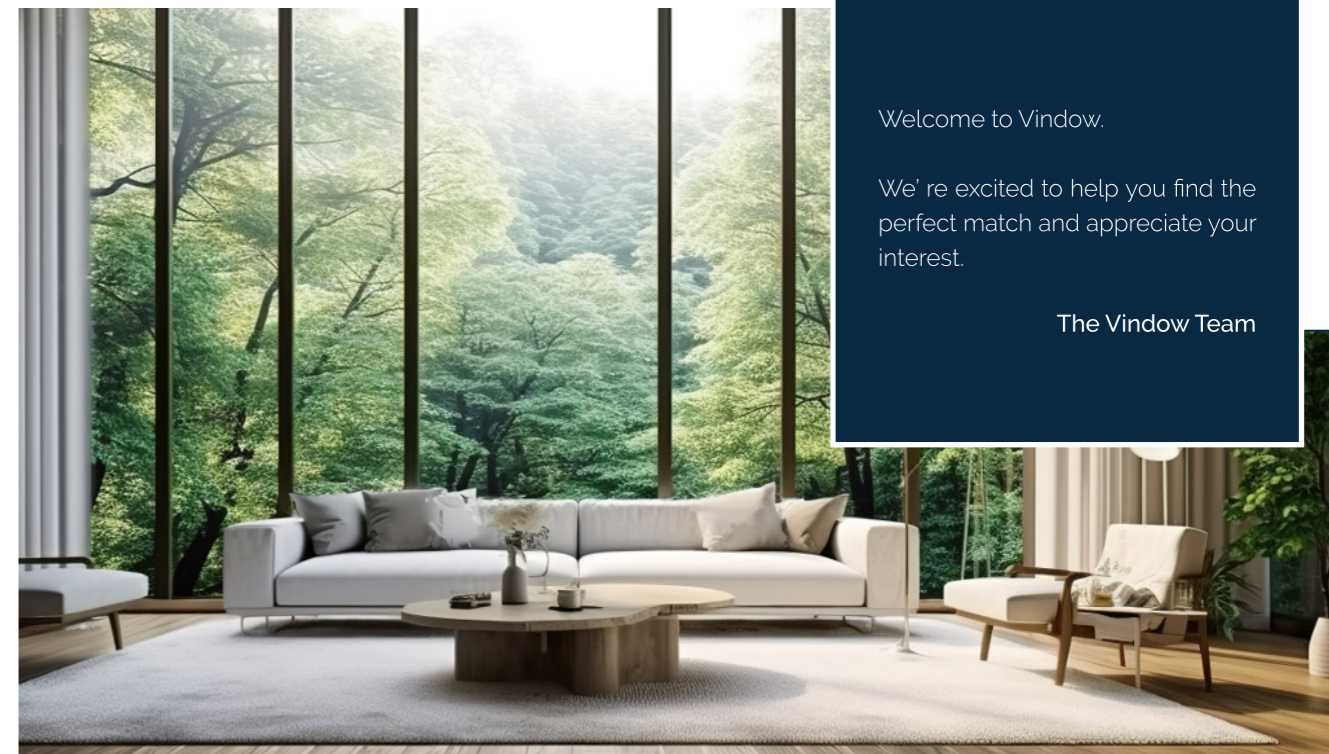

Welcome to Vindow.

We're excited to help you find the perfect match and appreciate your interest.

The Vindow Team

Home is where your story begins - let's write it together.

T_ 416.285.3347 (Canada and the USA)

T_ 416.285.3347 (Canada)

T_ 347.477.9899 (USA)

E_ sales@vindow.ca

W_ vindow.ca

Canada Office & Showroom:

117 Manville Rd., Toronto, ON M1L 4J7,
Canada

US Office:

300 South 4th St., 6th floor, Las Vegas,
NV 89101, USA